

Protein kinase D: a new player among the signaling proteins that regulate functions in the nervous system

Gang Li¹, Yun Wang^{1,2}

¹Neuroscience Research Institute and Department of Neurobiology, School of Basic Medical Sciences, Key Laboratory for Neuroscience, Ministry of Education/National Health and Family Planning Commission, Peking University, Beijing 100191, China

²PKU-IDG/McGovern Institute for Brain Research, Peking University, Beijing 100871, China

Corresponding author: Yun Wang. E-mail: wangy66@bjmu.edu.cn

© Shanghai Institutes for Biological Sciences, CAS and Springer-Verlag Berlin Heidelberg 2014

Protein kinase D (PKD) is an evolutionarily-conserved family of protein kinases. It has structural, regulatory, and enzymatic properties quite different from the PKC family. Many stimuli induce PKD signaling, including G-protein-coupled receptor agonists and growth factors. PKD1 is the most studied member of the family. It functions during cell proliferation, differentiation, secretion, cardiac hypertrophy, immune regulation, angiogenesis, and cancer. Previously, we found that PKD1 is also critically involved in pain modulation. Since then, a series of studies performed in our lab and by other groups have shown that PKDs also participate in other processes in the nervous system including neuronal polarity establishment, neuroprotection, and learning. Here, we discuss the connections between PKD structure, enzyme function, and localization, and summarize the recent findings on the roles of PKD-mediated signaling in the nervous system.

Keywords: PKD; neuronal polarity; pain modulation; neuroprotection; learning

Introduction

Members of the protein kinase D (PKD) family are diacylglycerol (DAG) and protein kinase C (PKC) effectors. They are activated by the actions of hormones, growth factors, neurotransmitters, and other stimuli through phospholipase C (PLC)^[1]. Three widely-expressed mammalian homologs are PKD1 (mouse PKD, human PKC μ)^[2, 3], PKD2^[3], and PKD3^[4] (also named PKC ν), but the levels of individual PKDs vary in different tissues. Recent findings have revealed that PKDs participate in the regulation of Golgi function through modulating the fission of vesicles from the trans-Golgi network (TGN)^[5, 6]. Other recent reports have shown that PKDs function during cell proliferation and apoptosis, carcinogenesis, and intracellular trafficking. Here, we describe the connections between PKD structure, enzymatic function, and localization, and then summarize recent findings on the roles of PKD in the

nervous system.

The PKD Family Belongs to the CaMK Group

The PKD family comprises PKD1, PKD2, and PKD3. PKD was initially described as an atypical isoform of the PKC family^[7], which is a member of the protein kinase A, G, and C (AGC) serine/threonine kinase subfamily^[8, 9]. However, later studies revealed that PKD has mixed features of different subclasses of the PKC family, so it does not belong to any one of them. For example, its pleckstrin-homology (PH) domain is closely related to the PKB and G-protein-coupled receptor kinase (GRK) families and is not found in any PKC enzyme, while the cysteine-rich domains are more reminiscent of classical and novel PKCs. The structure and function of the catalytic domain of PKD are quite different from those of the AGC/PKC family members^[2-4, 10]. Indeed, PKD has now been classified as a new family within the

CaMK group^[11], separate from the AGC group^[12]. Thus, the functions of protein kinases are most appropriately linked to their catalytic domain structures.

Protein Structure, Regulation, and Intracellular Localization

PKD1 has multiple domains: an N-terminal H-domain with a high proportion of apolar amino-acids, two cysteine-rich zinc-finger regions (C1A and C1B), a region rich in negatively-charged amino-acids, a PH domain, and a protein Ser/Thr kinase catalytic domain. Similar structures are found in PKD2 and PKD3 (Fig. 1). The elaborate constitution of PKD1 is intricately linked to its catalytic functions, regulation, and intracellular localization (Table 1). PKD1 can be activated through different pathways. First, some stimuli activate PLC, which induces PKD phosphorylation on the activation loop by PKC ϵ and/or PKC η directly (or indirectly)^[13-15]. For example, G-protein-coupled receptors or receptor tyrosine kinases that activate PLC and PKC ϵ or PKC η cause the phosphorylation of PKD at Ser744 and Ser748 in the activation loop^[16-19]. Second, G $\beta\gamma$ subunits directly activate PKD^[20-22]. The precise

mechanism of this activation *in vivo* needs to be defined. Third, the cleavage of PKD1 by caspase promotes its activation because it releases the inhibition of regulatory domains such as the zinc-fingers. This caspase-mediated activation of PKD1 has been demonstrated both *in vitro* and *in vivo*^[23].

The activity of PKD1 is controlled by its regulatory domains (Table 1). The two zinc-fingers C1A and C1B and the PH domain inhibit the kinase activity. Unlike other PH domains that bind to lipids, the PH domain in PKD1 can bind to several proteins. Mutations in the PH domain can activate PKD1^[17, 24, 25]. Deletion of the two zinc-fingers also fully activates PKD1^[26, 27].

PKD transportation to different destinations, such as the plasma membrane, nucleus, or Golgi apparatus, in response to different signaling pathways, is largely dependent on the interactions of the PKD regulatory domains with lipids or proteins. In resting cells, PKD is mostly located in the cytosol, with a smaller fraction in the Golgi apparatus. In some specialized cells, PKD also exists in the mitochondria^[28] and secretory granules^[29]. After activation through the PLC pathway, PKD1 is transported from the cytosol to the plasma membrane, then returns to

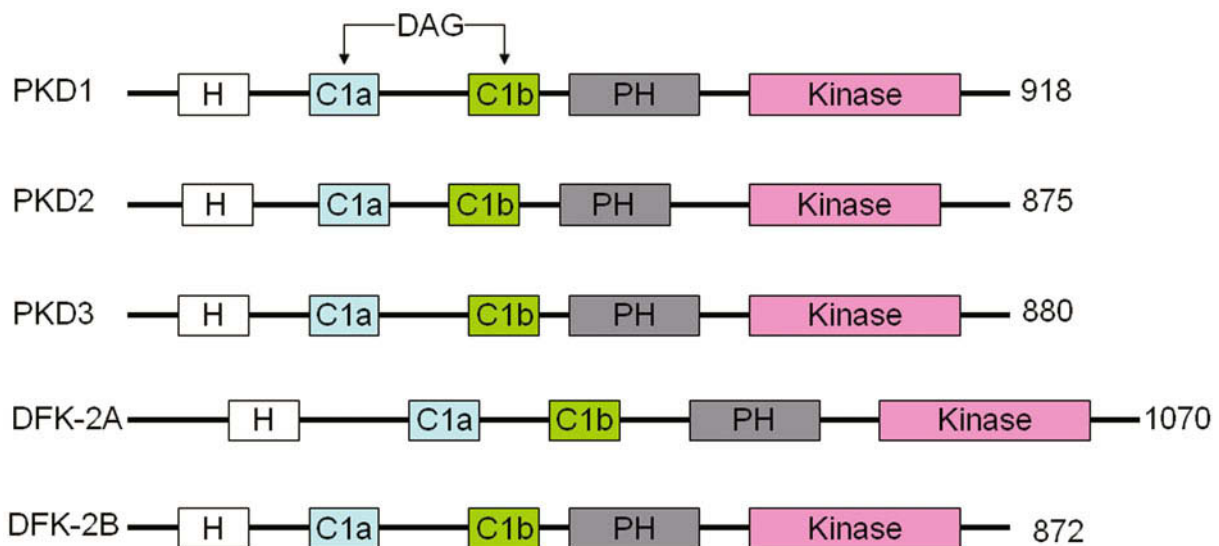

Fig. 1. Domain organization of protein kinase D (PKD) isoforms. Mammalian PKD1, PKD2, and PKD3 have an N-terminal H-domain with a high frequency of apolar amino-acids, highly-conserved DAG/PMA (phorbol-12-myristate-13-acetate)-binding regions (C1a and C1b), and PH and kinase domains. The amino-acid sequences of C1a, C1b, and the kinase domains of *Caenorhabditis elegans* (DFK-2A and DFK-2B) and mammalian PKDs are >70% identical. The number of amino-acids comprising individual PKD isoforms is shown on the right.

Table 1. Functions of the regulatory domains of protein kinase D (PKD)

Domain	Functions
C1A	Binding to diacylglycerol Recruitment of PKD to Golgi apparatus Negative regulation of PKD activity
C1B	Binding to diacylglycerol Transportation of PKD to the plasma membrane and into the nucleus Negative regulation of PKD activity
PH	Transportation of PKD out of the nucleus Negative regulation of PKD activity

the cytosol and enters the nucleus. Some PKD1 localization studies have relied on overexpression experiments; nonetheless, the localization of overexpressed GFP-tagged PKD and endogenous PKD is identical^[30, 31].

The PKD domains function differently during the process of localization (Table 1). As no interactions have been found between the PH domain of PKD1 and phosphorylated inositol lipids, which are important ligands responsible for membrane localization, this domain is not required for plasma membrane translocation^[31, 32] or Golgi localization^[33-39] like other PH-domain-containing AGC kinases, such as PKB and the GRKs. However, the PH domain is required for the nuclear export of PKD1^[22, 40]. The different lipid-binding specificity of the zinc-fingers C1A and C1B results in their different roles in targeting PKD1 to different destinations^[29, 33, 41-43]. Plasma membrane translocation of PKD1 is dependent on the C1B domain, while its Golgi localization requires the C1A domain and the phosphorylation of loop serines. After activation by G-protein-coupled receptors, PKD1 can shuttle between nucleus and cytosol, requiring the C1B domain for import and the PH domain for export from the nucleus^[22].

Biological Roles of PKD in the Nervous System

Role of PKD in Pain Modulation

Transient receptor potential vanilloid-1 (TRPV1) is a polymodal nociceptor activated by multiple stimuli^[44-46]. We first demonstrated that PKD1 phosphorylates rat TRPV1 at Ser116 and binds to the N-terminal of TRPV1. Furthermore, mutation of Ser116 (S to A) blocks both

TRPV1 phosphorylation by PKD1 and enhancement of the TRPV1 response to capsaicin^[47]. Thus, PKD1 is a direct regulator of TRPV1. Next, in an animal model of inflammatory hyperalgesia caused by complete Freund's adjuvant, an interaction between PKD1 and TRPV1 has been determined. We also found that PKD1 mediates the effect of heat hyperalgesia rather than mechanical hyperalgesia. The interaction between PKD1 and TRPV1 in dorsal root ganglia participates in the development and maintenance of inflammatory heat hypersensitivity^[48]. Our findings on the TRPV1 phosphorylation site and the involvement of PKD1 in inflammatory hyperalgesia have theoretical significance and provide a new target for the design of novel analgesics^[47-49].

Role of PKD in Neuronal Polarity

The development and maintenance of neuronal polarity is involved in nearly every aspect of neuronal signaling^[50, 51], and therefore is of great importance for neuronal functions. Early neurons have mechanisms similar to migrating cells for establishing the initial polarity. Our previous work^[52] has shown that PKD1 and PKD2 are essential for the establishment and maintenance of neuronal polarity. Loss-of-function of PKD disrupts polarized membrane trafficking and results in multiple axon formation, whereas PKD gain-of-function rescues the disrupted trafficking and polarity. Also, pre-existing dendrites can be converted to axons after PKD inhibition, suggesting that PKD1 and PKD2 also participate in the maintenance of polarity^[52]. Unlike other polarity proteins that interact with the cytoskeleton in neurites, PKD regulates polarity through its activity in the Golgi apparatus^[52]. The role of PKD in establishing

and maintaining polarity may be executed by regulating the TGN-derived sorting of dendritic and axon proteins. In hippocampal neurons, active PKDs are associated with the Golgi apparatus^[53]. Integral membrane proteins that later fuse with axon or dendrite are enveloped in TGN-derived vesicles and their sorting and packaging are regulated by PKD1^[53, 54]. This generates and maintains neuronal polarity, ultimately resulting in specialized postsynaptic functions. Alteration of PKD activity induces parallel changes in dendritic arborization. PKD knockdown increases the trafficking of proteins destined for dendritic membrane, but has no effect on vesicle fission^[54]. Thus, PKDs in hippocampal neurons bind to the Golgi apparatus to regulate the sorting, packaging, and targeting of different proteins, and suppress the endocytosis of dendritic membrane proteins, which are important for the establishment of cell polarity and dendritic specialization. One PKD effector candidate relevant to these processes is Kidins220. PKD1 phosphorylates the scaffold protein Kidins220^[55-58]. Kidins220 transportation from the TGN to the plasma membrane requires the autophosphorylation of PKD1 at Ser916. Kidins220 knockdown leads to the formation of multiple axons and abnormal dendritic branching. Kidins220 also binds to tubulin and microtubule-regulating molecules, which play an important role in neuronal morphogenesis. It is worth noting that loss-of-function of Kidins220 or PKD1/2 have a similar phenotype. They both cause multiple axons and aberrant dendrites, while leaving the Golgi apparatus integrity undisturbed. Consistently, Kidins220 knockdown does not change the total or active PKD. As Kidins220 traffic is associated with molecular motors that are important for the establishment of neuronal polarity, the function of the PKD-Kidins220 complex may be executed by regulating the polarized protein traffic. Kidins220 is also a cargo for kinesin-1 motor complex carriers, which drive the transport of multiple cargoes along the microtubule. It is noteworthy that kinesin-1 is related to the initial axonal specification during the establishment of polarity.

The evolutionarily conserved PARs (partitioning defective), including PAR-1, are also involved in the process of polarity establishment^[59-62]. Treatment with phorbol-12-myristate-13-acetate (PMA, a PKC activator), causes PKD-mediated PAR-1 phosphorylation and promotes its binding to 14-3-3, inducing PAR-1 dissociation from lateral

plasma membrane and inhibition of activity^[63]. These results suggest that PKD plays a role in regulating cell polarity *via* phosphorylation of PAR-1. However, evidence is still needed to confirm this important hypothesis with physiological stimuli rather than PMA treatment.

Role of PKD in Neuroprotection

During the early stage of oxidative stress, PKD1 can protect neurons. When dopaminergic neurons are exposed to H₂O₂ or 6-OHDA, PKD1 is activated. As PKC δ directly phosphorylates PKD1 *in vivo*, PKC δ loss-of-function may effectively inhibit PKD1 activation. It is worth noting that PKD1 loss-of-function by RNAi or overexpression of S916A PKD1 enhances oxidative stress-induced apoptosis, while PKD1 gain-of-function inhibits this apoptosis^[64]. Heat-shock protein 27 (HSP27) protects neurons during cerebral ischemia^[65] through phosphorylation at Ser15 and Ser82, critical sites for neuroprotection. PKD also directly phosphorylates HSP27^[66]. PKD loss-of-function abolishes the neuroprotective effects of HSP27^[67].

Role of PKD in Associative Learning

In *Caenorhabditis elegans*, PKD isoforms integrate external information into neuronal and intestinal epithelial cells to regulate learning and behavior^[68, 69]. Two PKD isoforms are found in *C. elegans*, encoded by the *dkf-2* gene. DKF-2B is located in neurons that construct the chemosensory circuitry, and DKF-2A is expressed in intestinal cells. Generally *C. elegans* displays chemotactic behavior toward Na⁺, while exposure to Na⁺ salts in the absence of food results in Na⁺ avoidance. The chemotaxis and avoidance of Na⁺ can be quantified accurately^[70-72]. The neurons that mediate the Na⁺ chemotaxis and learning express DKF-2B; disruption of *dkf-2* strongly suppresses Na⁺-dependent learning, but has no effect on Na⁺ detection or chemotaxis. Surprisingly, both neuronal DKF-2B and intestinal DKF-2A are essential for restoring the abnormal learning activity of *dkf-2* knockout animals. EGL-8 (a PLC β 4 homolog) and TPA-1 (a PKC δ homolog) control DKF-2B and DKF-2A *in vivo*. Animals with defective EGL-8 protein failed to learn to avoid 25 mmol/L Na⁺ after preincubation with 100 mmol/L sodium acetate. Defects in Na⁺-induced learning were qualitatively and quantitatively similar in *egl-8* and *dkf-2* single mutants and in *egl-8;dkf-2* double mutant. These results place EGL-8 and DKF-2A/2B in the same pathway and indicate that DAG production (or an increase in free cytoplasmic Ca²⁺ or both) is essential for salt taste-

induced learning. Meanwhile, TPA-1 depletion markedly impaired Na⁺-dependent learning (CI ~+0.4), yielding the same phenotype as DKF-2A and DKF-2B deficiency. These results indicate that TPA-1 regulates DKF-2B and DKF-2A *in vivo*. Thus, the DAG-PKD-mediated signaling pathway is required in both neurons and intestinal cells to generate Na⁺ avoidance^[73].

These data show that PKD is important in the nervous system. As the neuronal circuitry expresses DKF-2B, PKD might regulate the associative learning by modulating synaptic transmission. DKF-2A activation induces the secretion of a diffusible hormone that binds to neuronal receptors. Thus, DKF-2A might participate in behavioral

plasticity by mediating the starvation signal to neurons. This hypothesis needs further confirmation.

Concluding Remarks

Recent studies have shown that PKDs function as linkers between substrate effectors and the fundamental physiological processes regulated by DAG. PKD signaling regulating multiple biological processes in the nervous system has been largely revealed (Fig. 2). The priorities for the moment are the generation of mouse models, including PKD conditional knock-out and tissue-specific knock-in of mutated PKDs. The characterization of PKD mutants

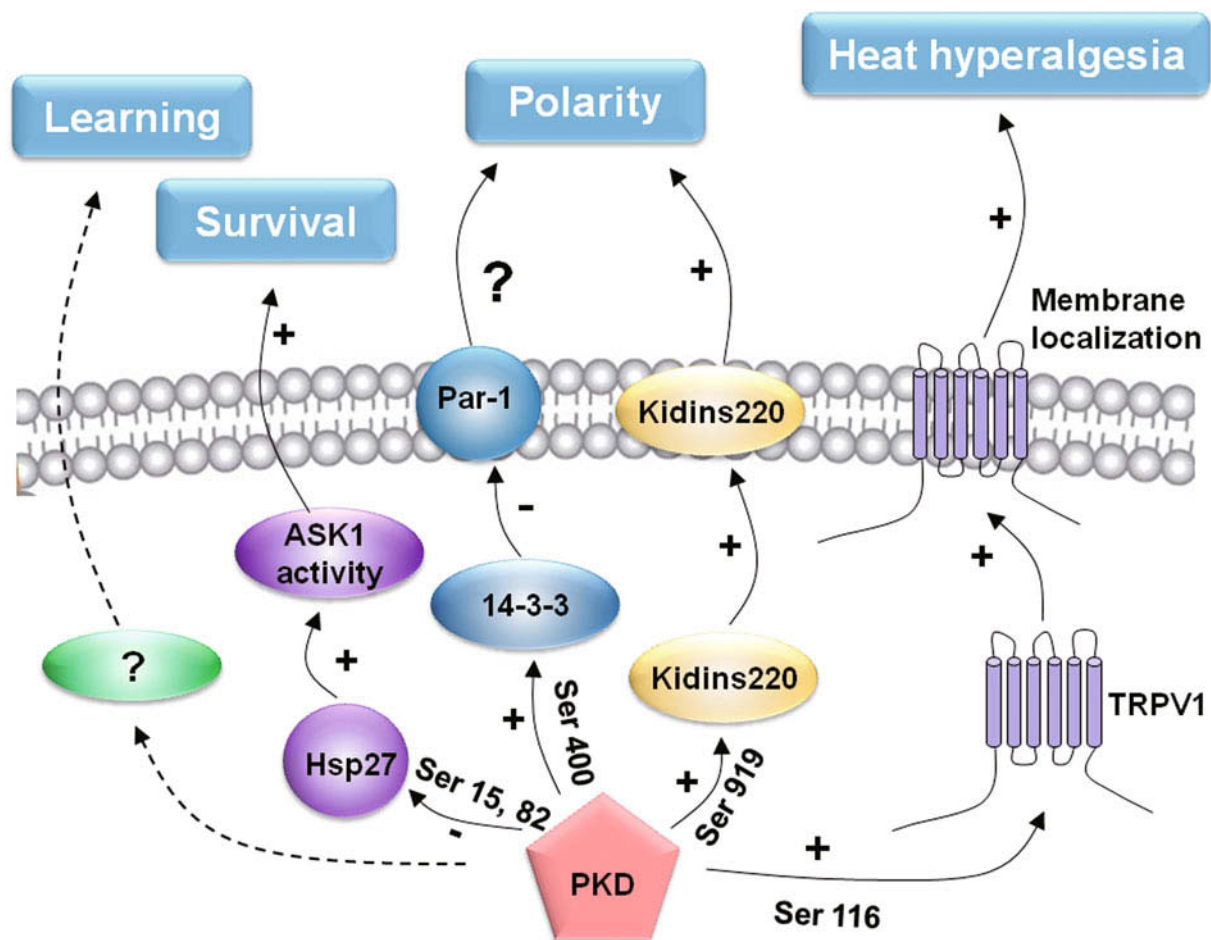

Fig. 2. PKD signaling regulates multiple biological processes in the nervous system. Broken lines represent processes in which PKD is implicated but the precise mechanism has not been elucidated. Solid lines indicate direct phosphorylation of substrates in the nervous system. The phosphorylation site of each substrate by PKD is presented. The plus signs indicate that PKD has a positive role while the minus sign represents negative role.

will help us to understand the consequences of PKD activation. The discovery of key roles for neuronal PKDs in associative learning in *C. elegans* suggests that the functions of mammalian PKD in synaptic plasticity, learning, and behavior should be assessed.

ACKNOWLEDGMENTS

This review was supported by the National Natural Science Foundation of China (81161120497, 30925015, 30830044, 30900582, and 81221002) and the National Basic Research Development Program (973 Program) of China (2014CB542204).

Received date: 2013-05-06; Accepted date: 2013-06-07

REFERENCES

- [1] Rozengurt E, Rey O, Waldron RT. Protein kinase D signaling. *J Biol Chem* 2005, 280: 13205–13208.
- [2] Hayashi A, Seki N, Hattori A, Kozuma S, Saito T. PKC ν , a new member of the protein kinase C family, composes a fourth subfamily with PKC μ . *Biochim Biophys Acta* 1999, 1450: 99–106.
- [3] Nishikawa K, Toker A, Johannes FJ, Songyang Z, Cantley LC. Determination of the specific substrate sequence motifs of protein kinase C isozymes. *J Biol Chem* 1997, 272: 952–960.
- [4] Valverde AM, Sinnott-Smith J, Van Lint J, Rozengurt E. Molecular cloning and characterization of protein kinase D: a target for diacylglycerol and phorbol esters with a distinctive catalytic domain. *Proc Natl Acad Sci U S A* 1994, 91: 8572–8576.
- [5] Liljedahl M, Maeda Y, Colanzi A, Ayala I, Van Lint J, Malhotra V. Protein kinase D regulates the fission of cell surface destined transport carriers from the trans-Golgi network. *Cell* 2001, 104: 409–420.
- [6] Yeaman C, Ayala MI, Wright JR, Bard F, Bossard C, Ang A, *et al.* Protein kinase D regulates basolateral membrane protein exit from trans-Golgi network. *Nat Cell Biol* 2004, 6: 106–112.
- [7] Johannes FJ, Prestle J, Eis S, Oberhagemann P, Pfizenmaier K. PKC μ is a novel, atypical member of the protein kinase C family. *J Biol Chem* 1994, 269: 6140–6148.
- [8] Newton AC. Regulation of protein kinase C. *Curr Opin Cell Biol* 1997, 9: 161–167.
- [9] Mellor H, Parker PJ. The extended protein kinase C superfamily. *Biochem J* 1998, 332: 281.
- [10] Sturany S, Van Lint J, Müller F, Wilda M, Hameister H, Höcker M, *et al.* Molecular cloning and characterization of the human protein kinase D2 a novel member of the protein kinase D family of serine threonine kinases. *J Biol Chem* 2001, 276: 3310–3318.
- [11] Hanks SK. Genomic analysis of the eukaryotic protein kinase superfamily: a perspective. *Genome Biol* 2003, 4: 111.
- [12] Johnson LN, Lowe ED, Noble ME, Owen DJ. The structural basis for substrate recognition and control by protein kinases. *FEBS Lett* 1998, 430: 1–11.
- [13] Vertommen D, Rider M, Ni Y, Waelkens E, Merlevede W, Vandenheede JR, *et al.* Regulation of protein kinase D by multisite phosphorylation identification of phosphorylation sites by mass spectrometry and characterization by site-directed mutagenesis. *J Biol Chem* 2000, 275: 19567–19576.
- [14] Iglesias T, Waldron RT, Rozengurt E. Identification of *in vivo* phosphorylation sites required for protein kinase D activation. *J Biol Chem* 1998, 273: 27662–27667.
- [15] Matthews SA, Rozengurt E, Cantrell D. Characterization of serine 916 as an *in vivo* autophosphorylation site for protein kinase D/protein kinase C μ . *J Biol Chem* 1999, 274: 26543–26549.
- [16] Waldron RT, Rey O, Iglesias T, Tugal T, Cantrell D, Rozengurt E. Activation loop Ser744 and Ser748 in protein kinase D are transphosphorylated *in vivo*. *J Biol Chem* 2001, 276: 32606–32615.
- [17] Waldron RT, Rozengurt E. Protein kinase C phosphorylates protein kinase D activation loop Ser744 and Ser748 and releases autoinhibition by the pleckstrin homology domain. *J Biol Chem* 2003, 278: 154–163.
- [18] Brändlin I, Hübner S, Eiseler T, Martinez-Moya M, Horschinek A, Hausser A, *et al.* Protein kinase C (PKC) η -mediated PKC μ activation modulates ERK and JNK signal pathways. *J Biol Chem* 2002, 277: 6490–6496.
- [19] Waldron RT, Iglesias T, Rozengurt E. The pleckstrin homology domain of protein kinase D interacts preferentially with the η isoform of protein kinase C. *J Biol Chem* 1999, 274: 9224–9230.
- [20] Jamora C, Yamanouye N, Van Lint J, Laudenslager J, Vandenheede JR, Faulkner DJ, *et al.* G $\beta\gamma$ -mediated regulation of Golgi organization is through the direct activation of protein kinase D. *Cell* 1999, 98: 59–68.
- [21] Añel AMD, Malhotra V. PKC η is required for β 1 γ 2/ β 3 γ 2- and PKD-mediated transport to the cell surface and the organization of the Golgi apparatus. *J Cell Biol* 2005, 169: 83–91.
- [22] Rey O, Sinnott-Smith J, Zhukova E, Rozengurt E. Regulated nucleocytoplasmic transport of protein kinase D in response to G protein-coupled receptor activation. *J Biol Chem* 2001, 276: 49228–49235.
- [23] Endo K, Oki E, Biedermann V, Kojima H, Yoshida K, Johannes FJ, *et al.* Proteolytic cleavage and activation of protein kinase C μ by caspase-3 in the apoptotic response of cells to 1- β -D-arabinofuranosylcytosine and other genotoxic

- agents. *J Biol Chem* 2000, 275: 18476–18481.
- [24] Iglesias T, Rozengurt E. Protein kinase D activation by mutations within its pleckstrin homology domain. *J Biol Chem* 1998, 273: 410–416.
- [25] Storz P, Döppler H, Johannes FJ, Toker A. Tyrosine phosphorylation of protein kinase D in the pleckstrin homology domain leads to activation. *J Biol Chem* 2003, 278: 17969–17976.
- [26] Iglesias T, Rozengurt E. Protein kinase D activation by deletion of its cysteine-rich motifs. *FEBS Lett* 1999, 454: 53–56.
- [27] Iglesias T, Matthews S, Rozengurt E. Dissimilar phorbol ester binding properties of the individual cysteine-rich motifs of protein kinase D. *FEBS Lett* 1998, 437: 19–23.
- [28] Storz P, Hausser A, Link G, Dedio J, Ghebrehiwet B, Pfizenmaier K, *et al.* Protein kinase C μ is regulated by the multifunctional chaperon protein p32. *J Biol Chem* 2000, 275: 24601–24607.
- [29] Matthews SA, Iglesias T, Rozengurt E, Cantrell D. Spatial and temporal regulation of protein kinase D (PKD). *EMBO J* 2000, 19: 2935–2945.
- [30] Hausser A, Link G, Bamberg L, Burzlaff A, Lutz S, Pfizenmaier K, *et al.* Structural requirements for localization and activation of protein kinase C μ (PKC μ) at the Golgi compartment. *J Cell Biol* 2002, 156: 65–74.
- [31] Rey O, Young SH, Cantrell D, Rozengurt E. Rapid protein kinase D translocation in response to G protein-coupled receptor activation dependence on protein kinase C. *J Biol Chem* 2001, 276: 32616–32626.
- [32] Matthews S, Iglesias T, Cantrell D, Rozengurt E. Dynamic redistribution of protein kinase D (PKD) as revealed by a GFP-PKD fusion protein: dissociation from PKD activation. *FEBS Lett* 1999, 457: 515–521.
- [33] Maeda Y, Beznoussenko GV, Van Lint J, Mironov AA, Malhotra V. Recruitment of protein kinase D to the trans-Golgi network via the first cysteine-rich domain. *EMBO J* 2001, 20: 5982–5990.
- [34] Ghanekar Y, Lowe M. Protein kinase D: activation for Golgi carrier formation. *Trends Cell Biol* 2005, 15: 511–514.
- [35] Baron CL, Malhotra V. Role of diacylglycerol in PKD recruitment to the TGN and protein transport to the plasma membrane. *Science* 2002, 295: 325–328.
- [36] Pfeffer S. Membrane domains in the secretory and endocytic pathways. *Cell* 2003, 112: 507–517.
- [37] Wang QJ. PKD at the crossroads of DAG and PKC signaling. *Trends Pharmacol Sci* 2006, 27: 317.
- [38] Bossard C, Bresson D, Polishchuk RS, Malhotra V. Dimeric PKD regulates membrane fission to form transport carriers at the TGN. *J Cell Biol* 2007, 179: 1123–1131.
- [39] Oancea E, Bezzerides VJ, Greka A, Clapham DE. Mechanism of persistent protein kinase D1 translocation and activation. *Dev Cell* 2003, 4: 561–574.
- [40] Auer A, von Blume J, Sturany S, von Wichert G, Van Lint J, Vandenheede J, *et al.* Role of the regulatory domain of protein kinase D2 in phorbol ester binding, catalytic activity, and nucleocytoplasmic shuttling. *Mol Biol Cell* 2005, 16: 4375–4385.
- [41] Irie K, Nakahara A, Ohigashi H, Fukuda H, Wender PA, Konishi H, *et al.* Synthesis and phorbol ester-binding studies of the individual cysteine-rich motifs of protein kinase D. *Bioorg Med Chem Lett* 1999, 9: 2487–2490.
- [42] Van Lint J, Rykx A, Maeda Y, Vantus T, Sturany S, Malhotra V, *et al.* Protein kinase D: an intracellular traffic regulator on the move. *Trends Cell Biol* 2002, 12: 193–200.
- [43] Rey O, Rozengurt E. Protein kinase D interacts with Golgi via its cysteine-rich domain. *Biochem Biophys Res Commun* 2001, 287: 21–26.
- [44] Szallasi A, Cortright DN, Blum CA, Eid SR. The vanilloid receptor TRPV1: 10 years from channel cloning to antagonist proof-of-concept. *Nat Rev Drug Discov* 2007, 6: 357–372.
- [45] Immke DC, Gavva NR. The TRPV1 receptor and nociception. *Semin Cell Dev Biol* 2006, 17: 582.
- [46] Cortright DN, Szallasi A. Biochemical pharmacology of the vanilloid receptor TRPV1. *Eur J Biochem* 2004, 271: 1814–1819.
- [47] Wang Y, Kedei N, Wang M, Wang QJ, Huppler AR, Toth A, *et al.* Interaction between protein kinase C μ and the vanilloid receptor type 1. *J Biol Chem* 2004, 279: 53674–53682.
- [48] Zhu H, Yang Y, Zhang H, Han Y, Li Y, Zhang Y, *et al.* Interaction between protein kinase D1 and transient receptor potential V1 in primary sensory neurons is involved in heat hypersensitivity. *Pain* 2008, 137: 574–588.
- [49] Wang Y. The functional regulation of TRPV1 and its role in pain sensitization. *Neurochem Res* 2008, 33: 2008–2012.
- [50] Craig AM, Banker G. Neuronal polarity. *Annu Rev Neurosci* 1994, 17: 267–310.
- [51] Dotti CG, Sullivan CA, Banker GA. The establishment of polarity by hippocampal neurons in culture. *J Neurosci* 1988, 8: 1454–1468.
- [52] Yin DM, Huang YH, Zhu YB, Wang Y. Both the establishment and maintenance of neuronal polarity require the activity of protein kinase D in the Golgi apparatus. *J Neurosci* 2008, 28: 8832–8843.
- [53] Czondor K, Ellwanger K, Fuchs YF, Lutz S, Gulyas M, Mansuy IM, *et al.* Protein kinase D controls the integrity of Golgi apparatus and the maintenance of dendritic arborization in hippocampal neurons. *Mol Biol Cell* 2009, 20: 2108–2120.
- [54] Bisbal M, Conde C, Donoso M, Bollati F, Sesma J, Quiroga S, *et al.* Protein kinase d regulates trafficking of dendritic

- membrane proteins in developing neurons. *J Neurosci* 2008, 28: 9297–9308.
- [55] Sánchez-Ruiloba L, Cabrera-Poch N, Rodríguez-Martínez M, López-Menéndez C, Jean-Mairet RM, Higuero AM, *et al.* Protein kinase D intracellular localization and activity control kinase D-interacting substrate of 220-kDa traffic through a postsynaptic density-95/discs large/zonula occludens-1-binding motif. *J Biol Chem* 2006, 281: 18888–18900.
- [56] Bracale A, Cesca F, Neubrand VE, Newsome TP, Way M, Schiavo G. Kidins220/ARMS is transported by a kinesin-1-based mechanism likely to be involved in neuronal differentiation. *Mol Biol Cell* 2007, 18: 142–152.
- [57] Higuero AM, Sánchez-Ruiloba L, Doglio LE, Portillo F, Abad-Rodríguez J, Dotti CG, *et al.* Kidins220/ARMS modulates the activity of microtubule-regulating proteins and controls neuronal polarity and development. *J Biol Chem* 2010, 285: 1343–1357.
- [58] Cabrera-Poch N, Sánchez-Ruiloba L, Rodríguez-Martínez M, Iglesias T. Lipid raft disruption triggers protein kinase C and Src-dependent protein kinase D activation and Kidins220 phosphorylation in neuronal cells. *J Biol Chem* 2004, 279: 28592–28602.
- [59] Benton R, Johnston DS. *Drosophila* PAR-1 and 14-3-3 inhibit Bazooka/PAR-3 to establish complementary cortical domains in polarized cells. *Cell* 2003, 115: 691–704.
- [60] Chen Y, Wang Q, Hu H, Yu P, Zhu J, Drewes G, *et al.* Microtubule affinity-regulating kinase 2 functions downstream of the PAR-3/PAR-6/atypical PKC complex in regulating hippocampal neuronal polarity. *Proc Natl Acad Sci U S A* 2006, 103: 8534–8539.
- [61] Lin D, Edwards AS, Fawcett JP, Mbamalu G, Scott JD, Pawson T. A mammalian PAR-3–PAR-6 complex implicated in Cdc42/Rac1 and aPKC signalling and cell polarity. *Nat Cell Biol* 2000, 2: 540–547.
- [62] Wu Q, DiBona VL, Bernard LP, Zhang H. The polarity protein partitioning-defective 1 (PAR-1) regulates dendritic spine morphogenesis through phosphorylating postsynaptic density protein 95 (PSD-95). *J Biol Chem* 2012, 287: 30781–30788.
- [63] Watkins JL, Lewandowski KT, Meek SE, Storz P, Toker A, Piwnicka-Worms H. Phosphorylation of the Par-1 polarity kinase by protein kinase D regulates 14-3-3 binding and membrane association. *Proc Natl Acad Sci U S A* 2008, 105: 18378–18383.
- [64] Asaithambi A, Kanthasamy A, Saminathan H, Anantharam V, Kanthasamy AG. Protein kinase D1 (PKD1) activation mediates a compensatory protective response during early stages of oxidative stress-induced neuronal degeneration. *Mol Neurodegener* 2011, 6: 43.
- [65] Stetler RA, Cao G, Gao Y, Zhang F, Wang S, Weng Z, *et al.* Hsp27 protects against ischemic brain injury via attenuation of a novel stress-response cascade upstream of mitochondrial cell death signaling. *J Neurosci* 2008, 28: 13038–13055.
- [66] Doppler H, Storz P, Li J, Comb MJ, Toker A. A phosphorylation state-specific antibody recognizes Hsp27, a novel substrate of protein kinase D. *J Biol Chem* 2005, 280: 15013–15019.
- [67] Stetler RA, Gao Y, Zhang L, Weng Z, Zhang F, Hu X, *et al.* Phosphorylation of HSP27 by protein kinase D is essential for mediating neuroprotection against ischemic neuronal injury. *J Neurosci* 2012, 32: 2667–2682.
- [68] Feng H, Ren M, Chen L, Rubin CS. Properties, regulation, and *in vivo* functions of a novel protein kinase D *Caenorhabditis elegans* DKF-2 links diacylglycerol second messenger to the regulation of stress responses and life span. *J Biol Chem* 2007, 282: 31273–31288.
- [69] Ren M, Feng H, Fu Y, Land M, Rubin CS. Protein kinase D (DKF-2), a diacylglycerol effector, is an essential regulator of *C. elegans* innate immunity. *Immunity* 2009, 30: 521.
- [70] Hukema RK, Rademakers S, Dekkers MP, Burghoorn J, Jansen G. Antagonistic sensory cues generate gustatory plasticity in *Caenorhabditis elegans*. *EMBO J* 2006, 25: 312–322.
- [71] Jansen G, Weinkove D, Plasterk RH. The G-protein {gamma} subunit gpc-1 of the nematode *C. elegans* is involved in taste adaptation. *Sci Signal* 2002, 21: 986.
- [72] Saeki S, Yamamoto M, Iino Y. Plasticity of chemotaxis revealed by paired presentation of a chemoattractant and starvation in the nematode *Caenorhabditis elegans*. *J Exp Biol* 2001, 204: 1757–1764.
- [73] Fu Y, Ren M, Feng H, Chen L, Altun ZF, Rubin CS. Neuronal and intestinal protein kinase d isoforms mediate Na⁺ (salt taste)-induced learning. *Sci Signal* 2009, 2: ra42.